

**ENERGIZER 321**

**SILVER OXIDE**

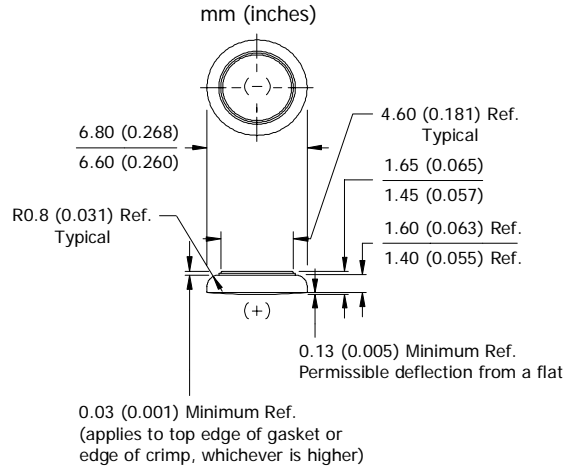

**Industry Standard Dimensions**



DESIGNED FOR USE ON CONTINUOUS LOW DRAIN

**Specifications**

- Chemical System:** Silver Oxide (Zn/Ag<sub>2</sub>O)
- Nominal Voltage:** 1.55 Volts
- Typical Capacity:** 15 mAh\* (to 1.3 volts)
- Capacity Test:** 94K ohm continuous drain at 21°C
- Typical Weight:** 0.28 grams (0.01 oz.)
- Typical Volume:** 0.07 cubic centimeters (0.004 cubic inch)
- Impedance (40 Hz):** 30 to 40 ohms

\* Varies according to the applied load, temperature, and cutoff voltage.

**Cross Section**

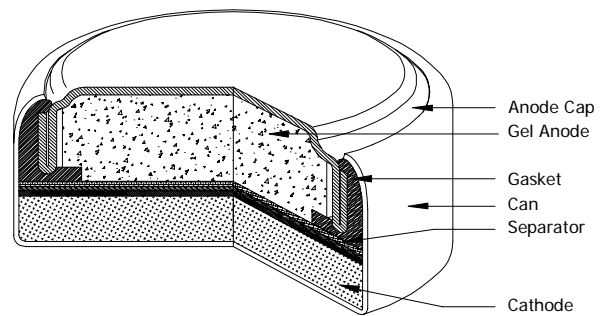

**Typical Discharge Characteristics**

Typical Performance at 21°C (70°F)

**Schedule:** Continuous  
**Typical Drain @1.55V:**  
0.016 milliamperes  
**Load:** 94K ohm

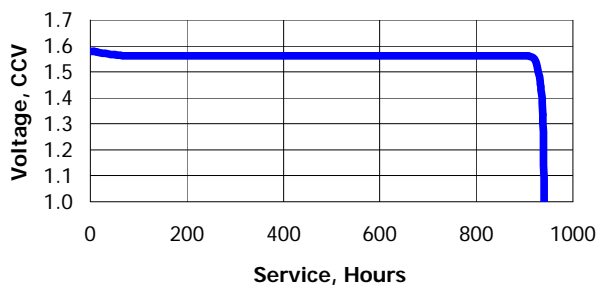

<u>Schedule</u>	<u>Typical Drains</u> at 1.55V (milliamperes)	<u>Load</u> (ohm)	<u>Cutoff</u> 1.3V (hours)
Continuous	0.016	94K	938

**Temperature Characteristics**

Typical Performance at Low Discharge Rates

**Service Effects**

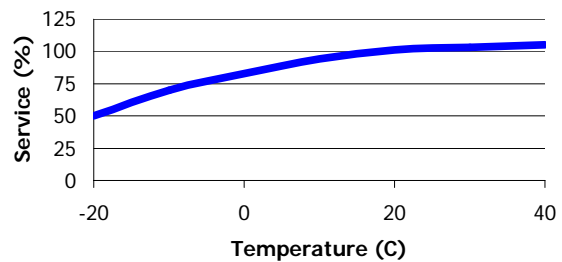

**Storage Effects**

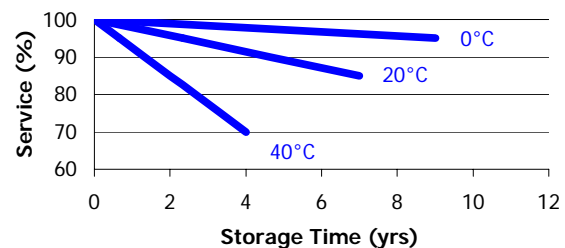

**Important Notice**

This datasheet contains typical information specific to products manufactured at the time of its publication.

©Energizer Holdings, Inc. - Contents herein do not constitute a warranty.