

**ENERGIZER 339**

**SILVER OXIDE**

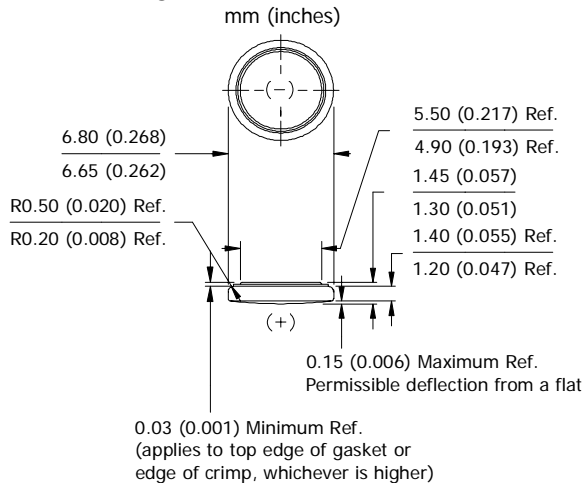

**Industry Standard Dimensions**



**Specifications**

- Chemical System:** Silver Oxide (Zn/Ag<sub>2</sub>O)
- Nominal Voltage:** 1.55 Volts
- Typical Capacity:** 13 mAh\* (to 1.3 volts)
- Capacity Test:** 68K ohm continuous drain at 21°C
- Typical Weight:** 0.22 grams (0.009 oz.)
- Typical Volume:** 0.053 cubic centimeters (0.003 cubic inch)
- Impedance (40 Hz):** 35 to 45 ohms

\* Varies according to the applied load, temperature, and cutoff voltage.

**Cross Section**

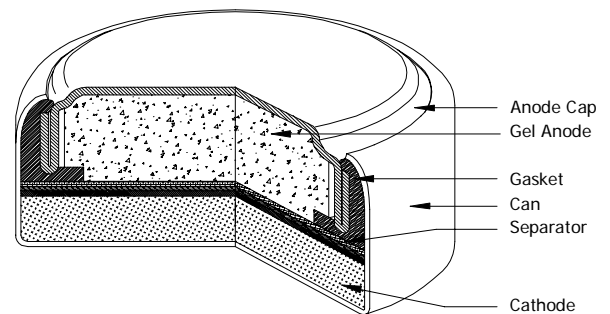

DESIGNED FOR USE ON CONTINUOUS LOW DRAIN

**Typical Discharge Characteristics**

Typical Performance at 21°C (70°F)

**Schedule:** Continuous  
**Typical Drain @1.55V:**  
0.023 milliamperes  
**Load:** 68K ohm

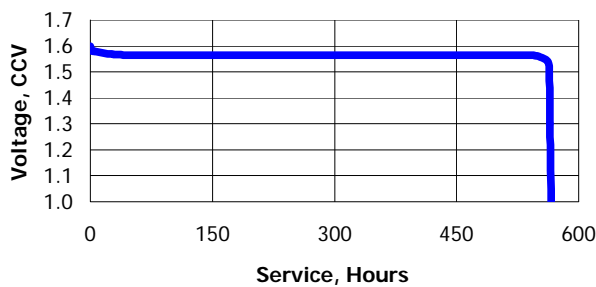

Schedule	Typical Drains at 1.55V (milliamperes)	Load (ohm)	Cutoff (hours)
Continuous	0.023	68K	565

**Temperature Characteristics**

Typical Performance at Low Discharge Rates

**Service Effects**

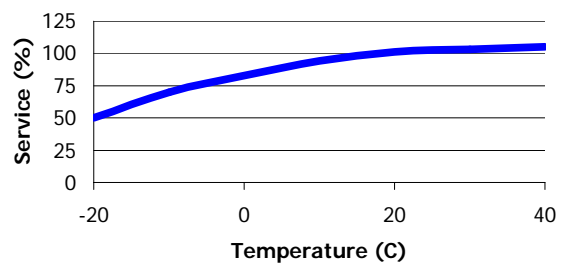

**Storage Effects**

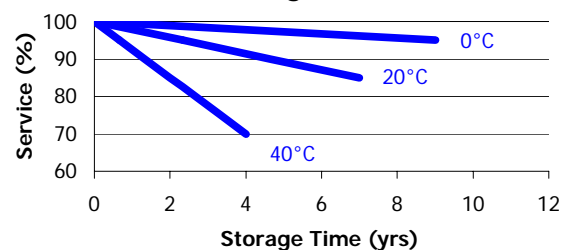

**Important Notice**

This datasheet contains typical information specific to products manufactured at the time of its publication.

©Energizer Holdings, Inc. - Contents herein do not constitute a warranty.