

ENERGIZER 344/350

SILVER OXIDE

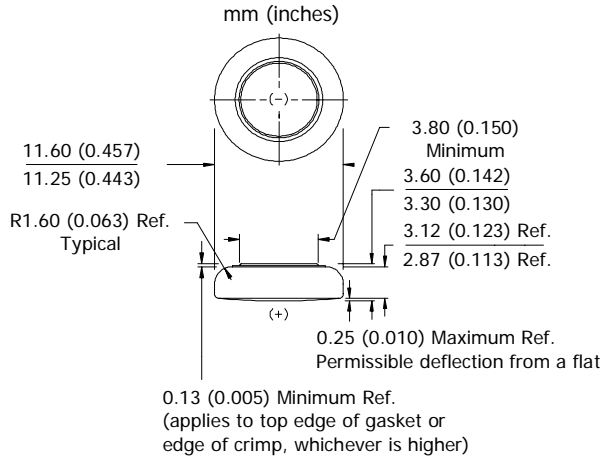

Industry Standard Dimensions



Specifications

Chemical System: Silver Oxide (Zn/Ag₂O)
Designation: IEC-SR42
Nominal Voltage: 1.55 Volts
Typical Capacity: 100 mAh* (to 1.3 volts)
Capacity Test: 8.2K ohm continuous drain at 21°C
Typical Weight: 1.6 grams (0.06 oz.)
Typical Volume: 0.38 cubic centimeters (0.023 cubic inch)
Impedance (40 Hz): 15 to 25 ohms

* Varies according to the applied load, temperature, and cutoff voltage.

Cross Section

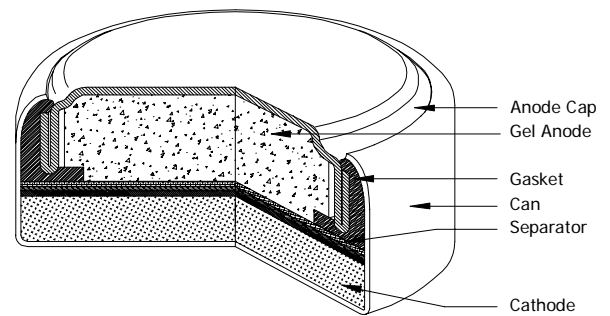

Typical Discharge Characteristics

Typical Performance at 21°C (70°F)

Schedule: Continuous
Typical Drain @1.55V:
 0.189 milliamperes
Load: 8.2K ohm

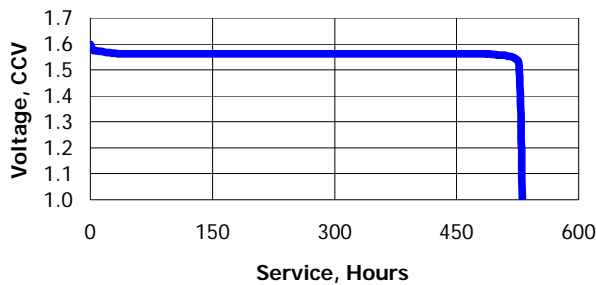

Schedule	Typical Drains at 1.55V (milliamperes)	Load (ohm)	Cutoff (hours)
Continuous	0.189	8.2K	529

Temperature Characteristics

Typical Performance at Low Discharge rates

Service Effects

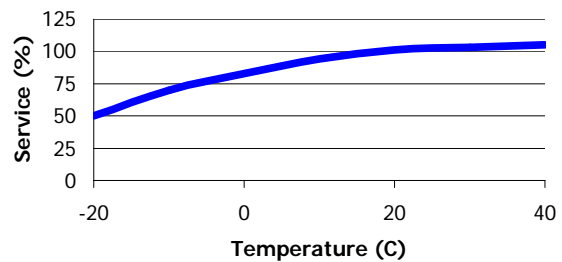

Storage Effects

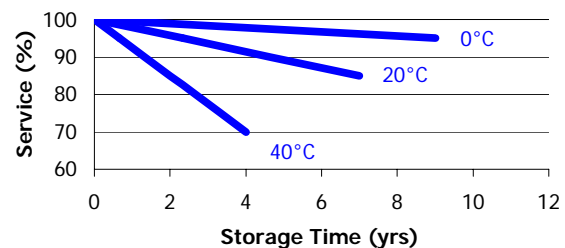

Important Notice

This datasheet contains typical information specific to products manufactured at the time of its publication.

©Energizer Holdings, Inc. - Contents herein do not constitute a warranty.