



World Headquarters
601 Rayovac Drive
Madison, WI 53711
Telephone 1-800-331-4522
Internet www.rayovac.com

Marketing Data Sheet - Batteries

S6600189
Issue R
Memo No: [MDSR1103](#)

Rayovac Stock Number: **903**

Name: **903 HEAVY DUTY CARBON ZINC**

ENGINEERING DATA:

Cell Chemistry: Carbon Zinc

Designation: ANSI/NEDA – 903

Nominal Voltage: 7.5 volts

Approximate Weight: 7.0 Lb (3.18 Kg)

Approximate Volume: 186 CU IN (3048 CU CM)

Operating Temp. Range: -30° C to 55° C (-20° F to 130° F)

Terminals: Screw

Shell: Plastic

Number Of Cells: 20

Environmental: Meets Environmental Protection Agency (EPA) Requirements For Landfill Disposal. No Mercury Added Formulation
[Rayovac Material Safety Data Sheets](#)

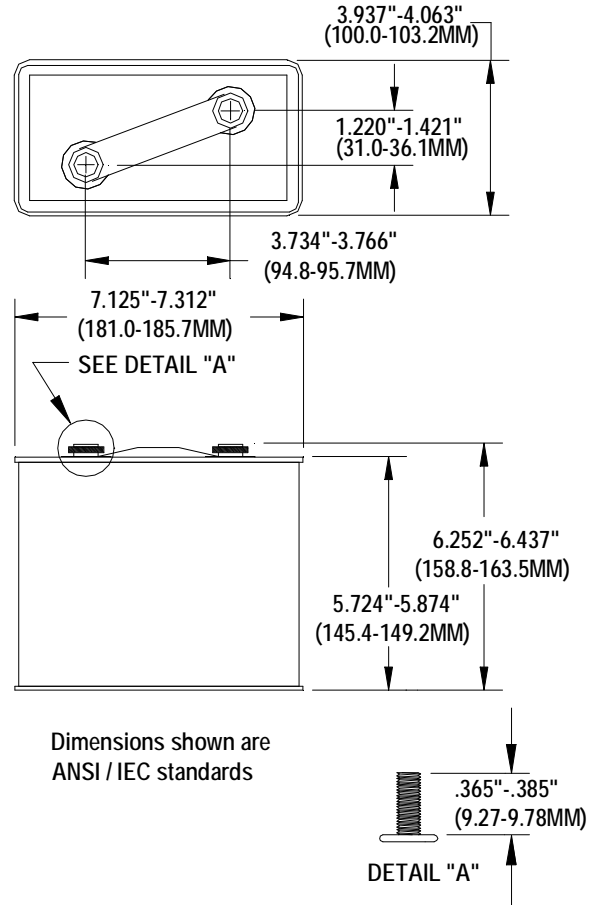

**TYPICAL INITIAL SERVICE AT 70°F (HOURS)
CUTOFF VOLTAGE**

APPLICATION DUTY CYCLE	LOAD (OHMS)	CURRENT (AMPS AT 6V)	CUTOFF VOLTAGE				mAh CAPACITY To 4.5V
			6.0V	5.5V	5.0V	4.5V	
PORTABLE LIGHT (30 MIN/HR-8 HR/DAY)	2.7	2.22	1.5	5.0	8.5	11.3	23,000
HIGH RATE RATING (24 HR/DAY)	2.7	2.22	1.4	4.5	7.0	10.0	20,000

This data is subject to change. Performance information is typical. Contents herein do not constitute a warranty.