

ENERGIZER NO. AC13

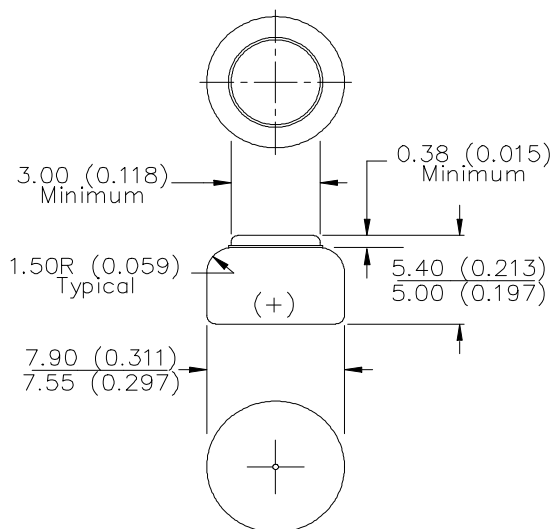

Industry Standard Dimensions in mm (inches)



Chemical System: Zinc Air (ZnO₂)

Designation: ANSI - 7000ZD, IEC - PR48

Battery Voltage: 1.4 Volts

Average Weight: 0.8 grams (0.03 oz.)

Volume: 0.3 cubic centimeters (0.02 cubic inch)

Average Capacity: 280 mAh to 0.9 volts
 (Rated at 1.5k ohms at 21°C & 50% RH)

Cells: AC13

TYPICAL DISCHARGE CHARACTERISTICS

Schedule: 16 hours/day

Typical Drain @ 1.3V: 1.3 & 0.87 milliamperes

Load: 1K & 1.5K ohms



Simulated Application Test Estimated Average Service at 21°C (70°F) and 50% RH

Schedule:	Typical Drains at 1.3V (milliamperes)	Load (ohms)	Cutoff Voltage
			0.9V
16 hours/day	1.3	1,000	215 Hours
16 hours/day	0.87	1,500	322 Hours

IMPEDANCE: The typical impedance of these cells on open circuit and during useful discharge varies from 5-20 ohms. This applies over a frequency range of 40-5,000 hertz and at the current drain shown above.

Important Notice

This data sheet contains information specific to batteries manufactured at the time of its publication.

Contents herein do not constitute a warranty.

Copyright © Eveready Battery Co. Inc. - All Rights Reserved

ENERGIZER AC13

Impedance vs. Frequency

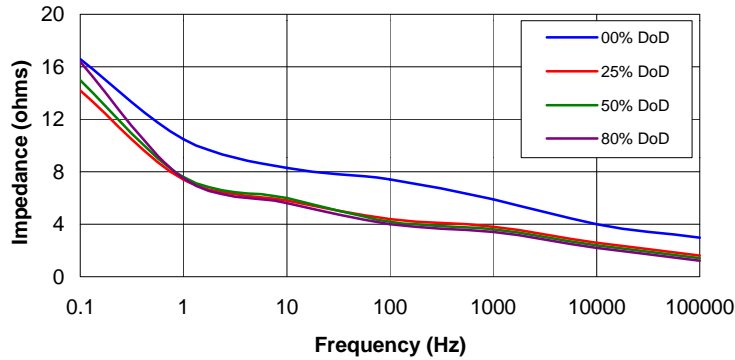

Impedance vs. Depth of Discharge

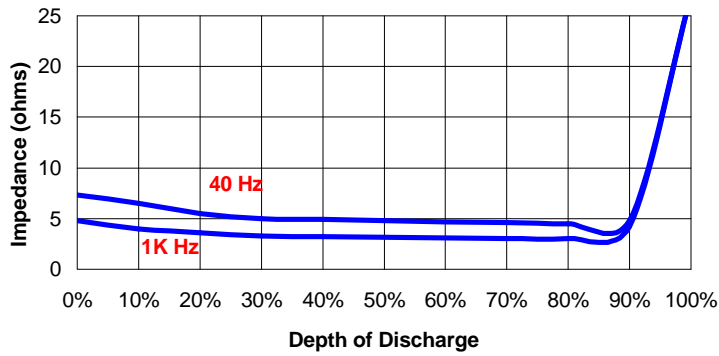

IMPEDANCE (Z) : The total opposition that a battery offers to a flow of alternating current.
Impedance is a combination of resistance and reactance

"AIR CELL" BATTERY - CUTAWAY VIEW

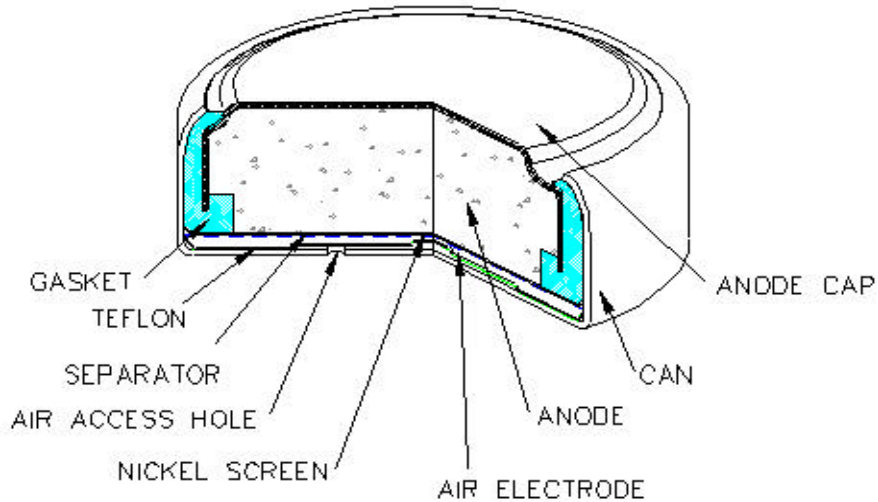

Important Notice

This data sheet contains information specific to batteries manufactured at the time of its publication.

Contents herein do not constitute a warranty.

Copyright © Eveready Battery Co. Inc. - All Rights Reserved