

SPECIFICATIONS CF-12V65DC

Nominal Voltage 12V

Nominal Capacity at 77°F (25°C)

Voltage readings are per cell

20 Hour Rate

(3.25 amps to 1.75 volts) 65 ampere hours

10 Hour Rate

(5.98 amps to 1.75 volts)..... 59.8 ampere hours

5 Hour Rate

(10.6 amps to 1.75 volts) 53 ampere hours

1 Hour Rate

(38 amps to 1.60 volts)..... 38 ampere hours

Max. Physical Size

Length 13.78 inches (350mm)

Width 6.57 inches (167mm)

Height (excluding terminals) 7.05 inches (179mm)

Height (including terminals) 7.20 inches (183mm)

Weight 48.9 lbs (22.2kg)

Energy Density

(20 Hour Rate) 1.26 watt hrs/cu in

(20 Hour Rate) 15.69 watt hrs/lbs

Operating Temperature Range

Discharge -60°F to +140°F (-51°C to +60°C)

Charge 0°F to +120°F (-18°C to +49°C)

Recharging Methods:

Float Charging: Constant Potential Source of 13.6 to 13.8 volts continuously.

Routine Charging: Constant Potential Source of 14.4 to 14.7 volts with a charging current of 19.5 ampere maximum.

Terminal: Standard is tin plated brass, bolt and nut

Case Material: Flame Retardant ABS



PRODUCT SCHEMATIC

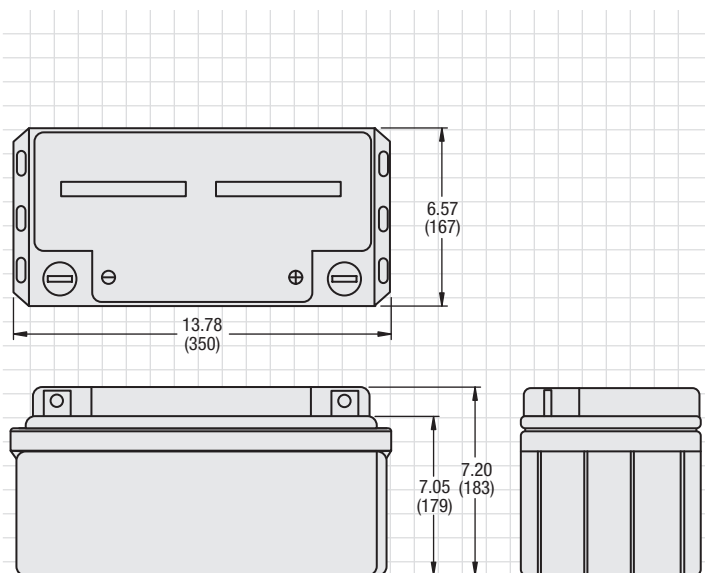

Above data are average values which can be obtained within 3 charge/discharge cycles. These are not minimum values.

Charging vs Temperature

The charging of Carefree batteries is best accomplished in a temperature range of 15°C to 32°C. Charging within this temperature range requires no temperature compensation. For applications over a wider temperature range, charging voltage must be changed as a function of temperature.

Capacity vs Temperature

The efficiency of the lead-acid system decreases as the temperature decreases and increases as temperature increases from room temperature (25°C) as illustrated. These four curves shown are based on discharges at the 20 hour, 5 hour, 1½ hour and 1 hour rates.

Self-Discharge Characteristics

High temperature increases the rate of self-discharge of all battery systems but even in this respect, the lead-calcium battery is perhaps least affected. In general, the rate of self-discharge can be expected to double for each 10°C rise in temperature above 20°C.

Battery Operating Conditions & Cautions

Battery contains toxic material (lead) and corrosive fluid (sulfuric acid) · Charging can produce explosive gases · Do not charge in gas tight enclosures · Charge battery in a well-ventilated area away from sparks, flames or smoking · Use approved voltage controlled charger · Do not short-circuit battery terminals, as this can cause an explosion or fire · Keep batteries and chargers away from children · Charge battery as soon as possible after use · Do not store battery in discharged state · Do not puncture, disassemble, mutilate or incinerate · MUST BE RECYCLED OR DISPOSED OF PROPERLY

Installation Care

All CAREFREE batteries are carefully assembled and with proper charging will provide excellent service. When placing the battery into service it must be inspected to make sure that the battery has not been damaged by rough handling. If the unit has been damaged, there is a possibility of a loss of a small amount of sulfuric acid electrolyte and possible corrosion of adjacent components. Any sulfuric acid can cause severe burns to the skin and eyes. If contact is made with a damaged battery, immediately wash the contacted area with water for at least 5 minutes. When installing the battery in equipment, ventilation must be provided. Toward the end of charge and under overcharge conditions, hydrogen and oxygen gas can be generated. If this gas is allowed to accumulate in the enclosure and a spark is introduced, an explosion could result.

The specifications on this sheet may be changed by EaglePicher Technologies, LLC, without notice.

Capacity as Affected by Temperature

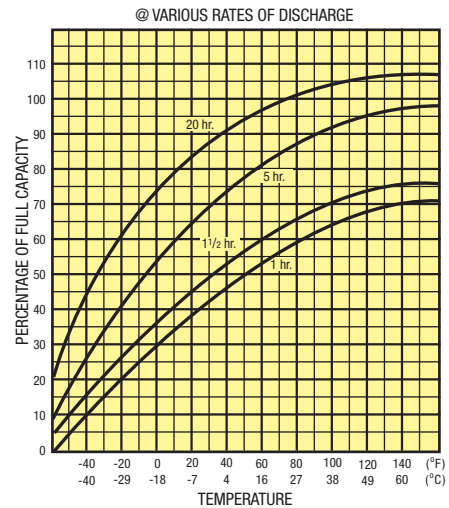

Typical Voltage Characteristic (25°C)

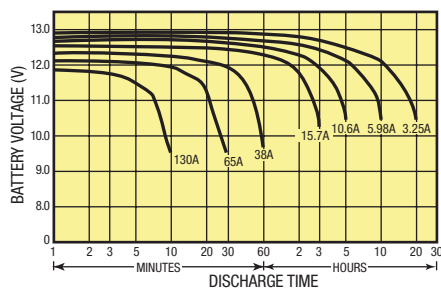

Typical Self-Discharge Characteristics

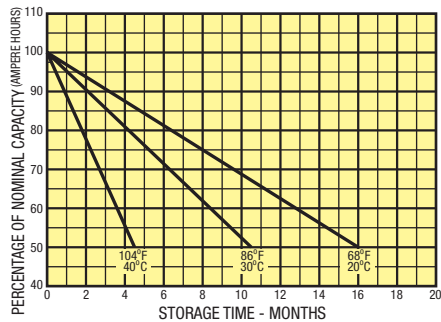

Cycle Service Life In Relation To Depth of Discharge

