

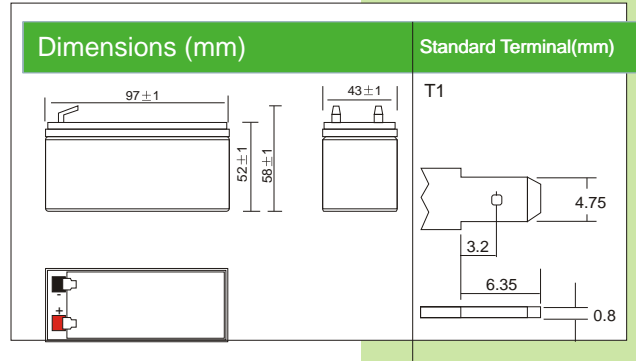

DJW12-1.2(12V1.4AH)



Physical Specification		
Nominal Voltage		12V
Nominal Capacity (20HR)		1.4AH
Dimension	Length	97 ± 1mm (3.82 inches)
	Width	43 ± 1mm (1.69 inches)
	Container Height	52 ± 1mm (2.04 inches)
	Total Height (with Terminal)	58 ± 1mm (2.28 inches)
Weight		Approx 0.6kg (1.32lbs)
Standard Terminal		T1(standard)

Discharging Current & Discharge Duration Time

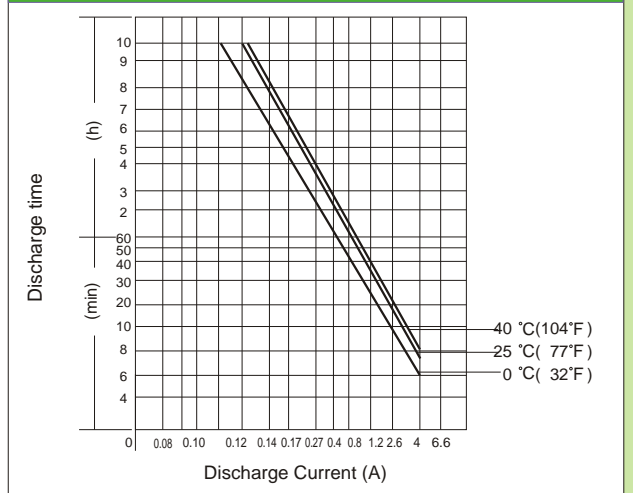

Electrical Specification					
Rated Capacity	20 hour rate (70 mA)	1.4AH	Constant-Voltage Charge	Cycle	Initial Charging Current less than 0.36A. Voltage 14.4V~ 15.0V at 25°C (77°F) Temp. Coefficient -30mV/C
	10 hour rate (130mA)	1.3AH			
	5 hour rate (240mA)	1.2AH			
	1 hour rate (850mA)	0.85AH			
	15minute rate (2.6 A)	0.65AH			
Capacity affected by Temperature	40C (104F)	103%	Charge	Standby	No limit on Initial Charging Current Voltage 13.5V~13.8V at 25C (77°F) Temp. Coefficient - 20mV/C
	25C (77F)	100%			
	0C (32F)	86%			

Discharge Characteristics (25°C, 77°F)

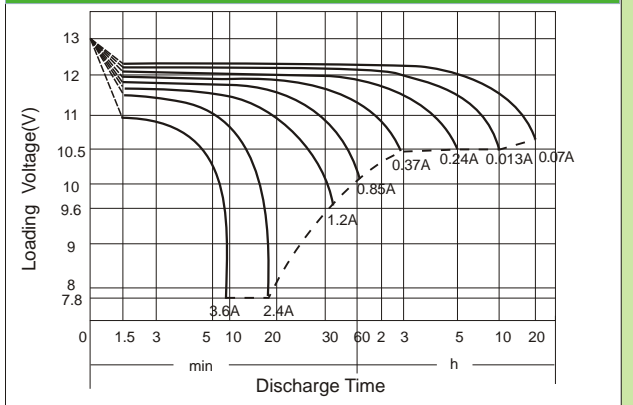

Constant Current (Amp) and Constant Power (Watt) Discharge Table (25°C, 77°F)

Time(minute) Final voltage/Cell	5	10	15	20	30	45	60	120	180	300	600	1200
Amp/Watt/Cell	1.3	1.3	1.3	1.3	1.6	1.6	1.67	1.7	1.75	1.75	1.75	1.8
A	6.37	3.90	2.60	2.24	1.63	1.17	0.85	0.51	0.37	0.24	0.13	0.07
W	10.79	7.42	5.04	4.39	3.21	2.33	1.68	1.01	0.73	0.48	0.26	0.14