

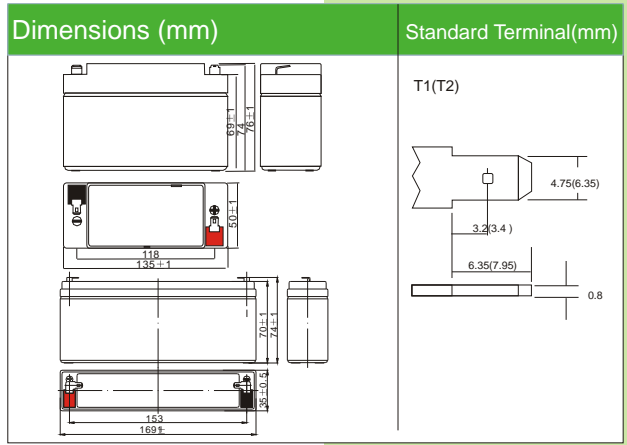

# DJW6-5.0(6V5.2AH)

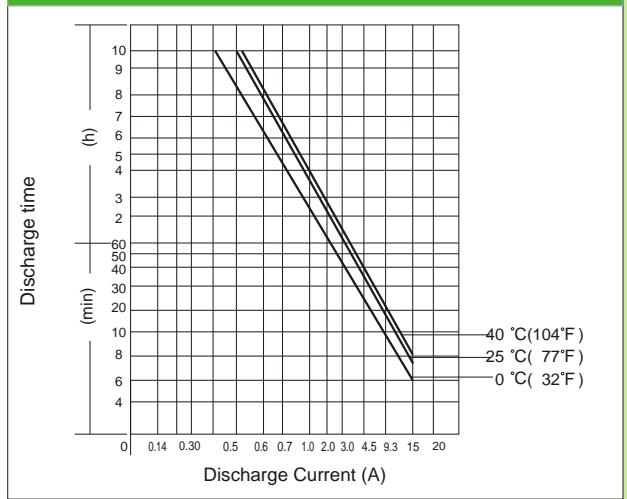

## Discharging Current & Discharge Duration Time



## Physical Specification

Nominal Voltage		6V	6V
Nominal Capacity (20HR)		5.2AH	5.2AH(LH)
Dimension	Length	169±1mm (6.65 inches)	135±1mm (5.31 inches)
	Width	35±1mm (1.38 inches)	50±1mm (1.97 inches)
	Container Height	70±1mm (2.75 inches)	76±1mm (2.99 inches)
	Total Height (with Terminal)	74±1mm (2.91 inches)	76±1mm (2.99 inches)
Weight		Approx. 1.05kg (2.34lbs)	Approx. 1.17kg (2.58lbs)
Standard Terminal		T1	T2

## Electrical Specification

Rated Capacity	20 hour rate (0.26A)	5.2AH	Cycle	Initial Charging Current less than 1.50A. Voltage 7.20V~7.50V at 25°C (77°F) Temp. Coefficient -15mV/°C
	10 hour rate (0.48 A)	4.8AH		
5 hour rate (0.84A)	4.2AH	Standby		
1 hour rate (3.2 A)	3.2AH		No limit on Initial Charging Current Voltage 6.75V~6.90V at 25°C (77°F) Temp. Coefficient -10mV/°C	
15minute rate(10.19 A)	2.55AH			
Capacity affected by Temperature	40C (104F)	103%		
	25C (77F)	100%		
	0C (32F)	86%		

## Discharge Characteristics (25°C, 77°F)

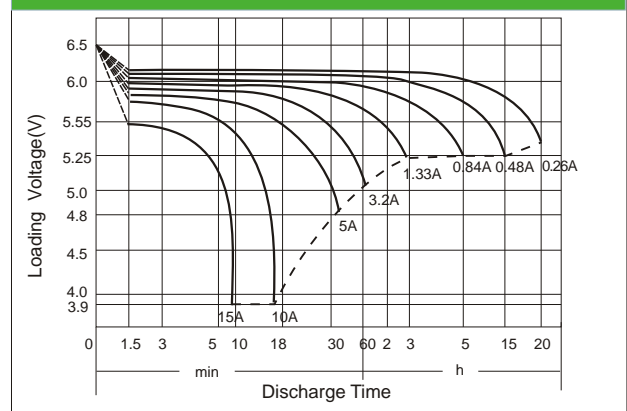

## Constant Current (Amp) and Constant Power (Watt) Discharge Table (25°C, 77°F)

Time(minute) Final voltage/Cell	Amp/Watt/Cell												
	5	10	15	20	30	45	60	120	180	300	600	1200	
A	20.80	14.82	10.19	8.32	5.98	4.16	3.20	1.82	1.33	0.84	0.48	0.26	
W	37.23	27.87	19.40	16.28	11.75	8.27	6.40	3.62	2.64	1.68	0.96	0.52	