

ER3S

Model	ER3S	
System	Li-Thionyl Chloride/Inorganic Electrolyte	
Nominal Voltage (V)	3.6	
Nominal Capacity (mAh)*	790	
Nominal Discharge Current (μA)	35	
Temperature Ranges (deg. C)	min.	max.
Operating	-40	+85
Weight (g)**	7	
Dimensions (mm)**		
Diameter	14.5	
Height	26	
UL Recognition	MH12568 (N)	

Available Terminals and Wire Connectors

Check http://www.maxell.co.jp/e/products/industrial/battery/pdf/er3se_.pdf for diagrams of batteries with terminals.

Characteristics

● Discharge Characteristics

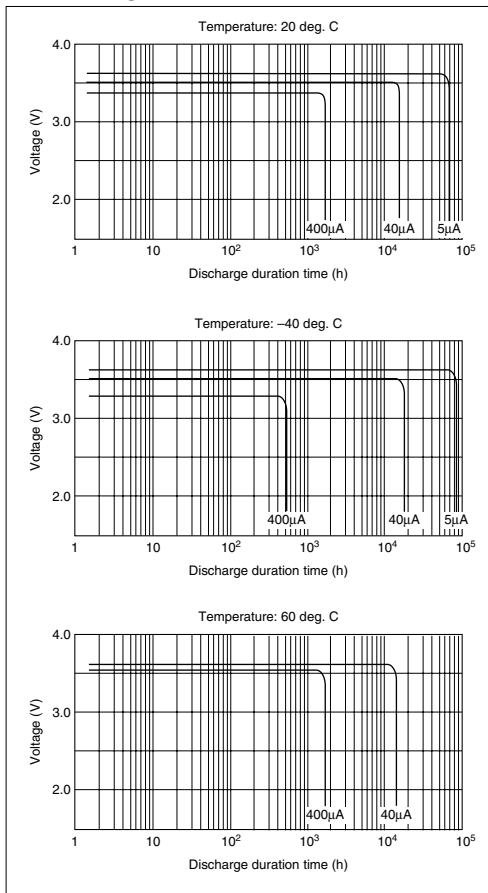

● Relationship between Discharge Current and Duration Time

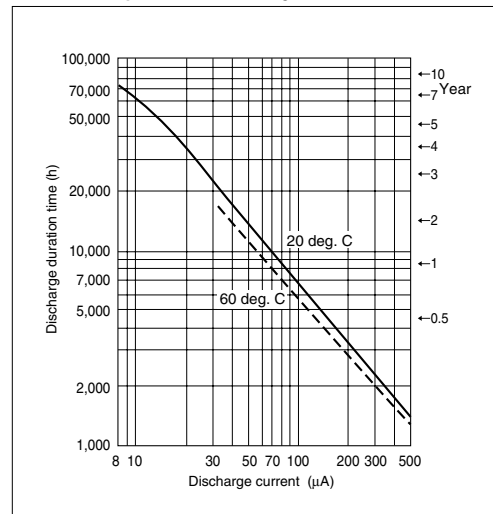

● Storage Characteristics

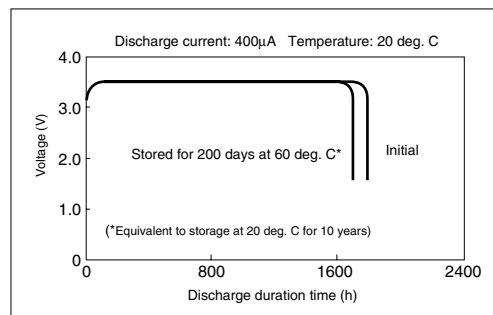

* Nominal capacity indicates duration until the voltage drops down to 2.0V when discharged at a nominal discharge current at 20 deg. C.
 ** Dimensions and weight are for the battery itself, but may vary depending on the shape of terminals or other factors.

ER Lithium Thionyl Chloride Batteries

Safety Instructions

This battery is a high energy density sealed battery containing dangerous (Lithium) and deleterious (Thionyl Chloride) materials. For this reason, improper handling of the battery could lead to distortion, leakage*, overheating, explosion, fire, or generation of irritating/corrosive gases, causing bodily injury or equipment trouble. Please observe the following instructions to prevent accidents.

For from your customers to your industrial waste processors (including recycled processor), please have them fully understand these instructions.

(* Leakage is defined as the unintentional escape of a liquid from a battery.)

WARNING Handling

Never swallow.

Always keep the battery out of the reach of infants and young children to prevent it from being swallowed. If swallowed, consult a physician immediately.

Never apply an excessive force to the positive terminal.

Because the positive terminal is sealed by a glass, subjecting this area to sudden jolts and excessive force (over 19.6 N) could destroy the glass seal. This could cause leakage and the generation of irritating/corrosive gases.

Never drop

Dropping the battery could destroy the glass seal leading to leakage and the generation of irritating/corrosive gases.

Never weld the terminals or weld a wire to the body of the battery directly.

The heat of welding or soldering could cause the lithium to melt, or cause damage to the insulating material in the battery, leading to possible distortion, leakage, overheating, explosion, or fire, or generation of irritating/corrosive gases. When soldering the battery directly to equipment, solder only the tabs or leads. Even then, the temperature of the soldering iron must be below 350 deg. C and the soldering time less than 5 seconds. Do not use a soldering bath, because the circuit board with battery attached could stop moving or the battery could drop into the bath. Moreover do not use excessive solder, because the solder could flow to unwanted portions of the board, leading to a short-circuit or charging of the battery.

Never short-circuit the battery.

Do not allow the positive and negative terminals to short-circuit. Never carry or store the battery with metal objects as a necklace or a hairpin. Otherwise, this could lead to distortion, leakage, overheating, explosion, fire, or generation of irritating/corrosive gases.

Never charge.

The battery is not designed to be charged by any other electrical source. Charging could generate gas and internal short-circuiting, leading to distortion, leakage, overheating, explosion, fire, or generation of irritating/corrosive gases.

Never forcibly discharge.

Forcibly discharging by an external power source or other batteries could cause the voltage to fall below 0V (reversing the poles), generating gas inside the battery and leading to distortion, leakage, overheating, explosion, fire, or generation of irritating/corrosive gases.

Never heat.

Heating the battery to more than 100 deg. C could increase the internal pressure, causing distortion, leakage, overheating, explosion, fire, or generation of irritating/corrosive gases.

Never expose to open flames.

Exposing to flames could cause the lithium metal to melt, causing the battery to catch on fire and explode.

Never disassemble the battery.

Disassembly could generate the irritating/corrosive gases. In addition, the lithium metal inside the battery could overheat, leading to catch on fire.

Never deform.

Deforming could cause leakage, overheating, explosion, fire, or generation of irritating/corrosive gases.

Never reverse the positive and negative terminals when mounting.

Improper mounting of the battery could lead to short-circuiting, charging or forced-discharging. This could cause distortion, leakage, overheating, explosion, fire, or generation of irritating/corrosive gases.

Never use different batteries together.

Using different batteries together, i.e. different type or used new or different manufacturer could cause distortion, leakage, overheating, explosion, fire, or generation of irritating/corrosive gases because of the differences in battery property. If using two or more batteries connected in series or in parallel even same batteries, please consult with Maxell before using.

Never allow liquid leaking from the battery to get in your eyes or mouth.

Because this liquid could cause serious damage, if it does come in contact with your eyes, flush them immediately with plenty of water and consult a physician. Likewise, If the liquid gets in your mouth, rinse immediately with plenty of water and consult a physician.

Never touch the battery electrodes.

Do not allow the battery electrodes to come in contact with your skin or fingers. Otherwise, the moisture from your skin could cause a discharge of the battery, which could produce certain chemical substances causing you to receive a chemical burns.

ER Lithium Thionyl Chloride Batteries

WARNING Circuit Design for Back-up Use

This is a primary battery and cannot be charged. If used in memory or RTC back-up applications, be sure to use diodes to prevent charging from the main power source or other batteries, and protective resistance to regulate the current as shown in the figure below. Note that the points described below should be taken into careful consideration when selecting diodes and protective resistance.

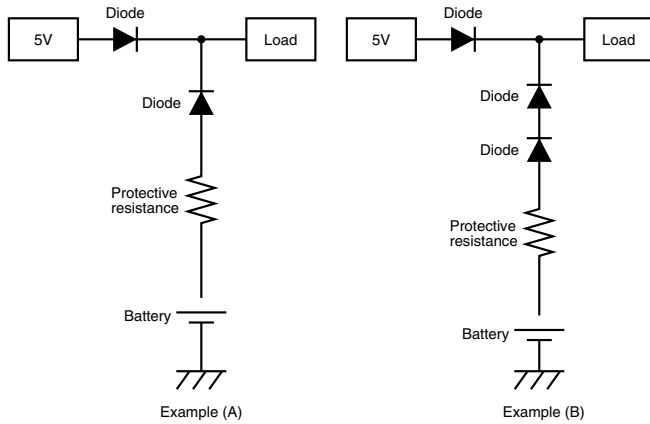

Type	Maximum Current
ER17/50H	125μA
ER17/50	125μA
ER6	100μA
ER6C	100μA
ER17/33	70μA
ER3	50μA
ER3S	40μA

Supplied voltage to load

Because a diode and a resistance generate the voltage drop on operating, please take into consideration these voltage drops for supplied voltage to load.

Using diodes to prevent charging

Please choose diodes with leak current of no more than 0.5μA.

Using and setting protective resistance

Protective resistance is used to prevent the battery from being charged by large surges of current during diode failure. Please set the resistance so that the maximum current shown in the right table is not exceeded. For example, say an ER6 battery is used in sample circuit A in combination with a main power source 5 volt. Since the permitted charge current is 100μA and this battery's voltage is 3.6V, let resistance be $R \geq (5V - 3.6V) / 100\mu A = 14k$ ohm, meaning that at least 14k ohm is required.

Note: If the diodes broke down, it is necessary for safety to replace them as soon as possible even though using protective resistance. Considering the trouble of diodes and resistance, other safety measures should be incorporated in the circuit design.

WARNING Disposal

The battery may be regulated by national or local regulation. Please follow the instructions of proper regulation. As electric capacity is left in a discarded battery and it comes into contact with other metals, it could lead to distortion, leakage, overheating, or explosion, so make sure to cover the (+) and (-) terminals with friction tape or some other insulator before disposal.

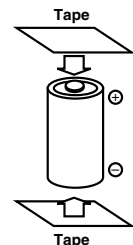

CAUTION Handling

(Example of battery insulation)

Minimum transient voltage

The various tests have shown that the minimum transient voltage is influenced greatly by the actual conditions of use and storage. Therefore, please design your circuits using no more than the standard discharge current, taking into account the voltage drop due to the minimum transient voltage. Please consult with Maxell beforehand if you are unsure of anything.

Installing, removing, and disposing of batteries

- 1) When installing a battery in a device, make sure that the positive terminal is facing up, or at least to the side. As this battery uses liquid thionyl chloride as the positive active material, placing the positive terminal at the bottom will cause the thionyl chloride to become maldistributed, which could prevent the needed performance from being obtained when a large amount of current is used.
- 2) Please have the installation, removal, and disposal of this battery performed by a technician with a thorough understanding of the Warnings and Cautions on handling.

Storage

Avoiding storing the battery in direct sunlight, or in excessively hot and humid locations, and store it out of the way of rainwater and other adverse environmental elements.

Bundling

When bundling the battery with a product, be sure to use cushioning and other packing to protect the battery (and especially the positive terminal) from jolts and shocks during transportation.

* Nominal capacity indicates duration until the voltage drops down to 2.0V when discharged at a nominal discharge current at 20 deg. C.
 ** Dimensions and weight are for the battery itself, but may vary depending on the shape of terminals or other factors.