

PE12V12

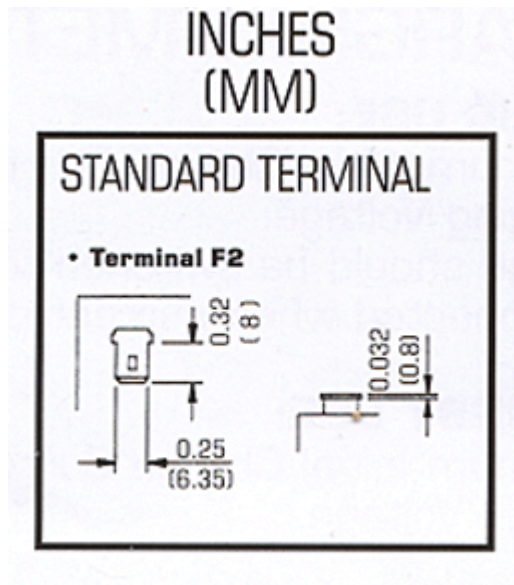

Dimensions



Rechargeable Sealed Lead Acid Battery Specifications

1	Nominal Voltage	12V
2	Nominal Capacity	0.05C (0.06A to 10.50V) 12.0 AHr 0.1C (0.12A to 10.50V) 10.80 AHr 0.2C (0.24A to 10.20V) 9.36 AHr 1C (0.20A to 9.00V) 6.24 AHr
3	Weight (Approx.)	9.25 lbs. (4.35 kg)
4	Internal Resistance of fully charged battery	12 milliohms
5	Energy Density (0.05C)	1.70 Watt-hours/cubic inch (103.5 Watt-hours/ℓ)
6	Specific Energy (0.05C)	15.6 Watt-hours/pound (34.3 Watt-hours/ℓ)
7	Maximum Discharge Current with standard terminals	72 amperes
8	Maximum Short Duration Discharge Current (less than 5 sec.)	180 amperes
9	Vibration Test	(2000 cycles/minute, 0.10 excursion, 2 hours) No loss in capacity or performance
10	Charge Retention (shelf life)	% of nominal capacity at 77°F (25°C) 1 month 97% 3 months 91% 6 months 85%
11	Operating Temperature Range	Charge 32°F (0°C) to

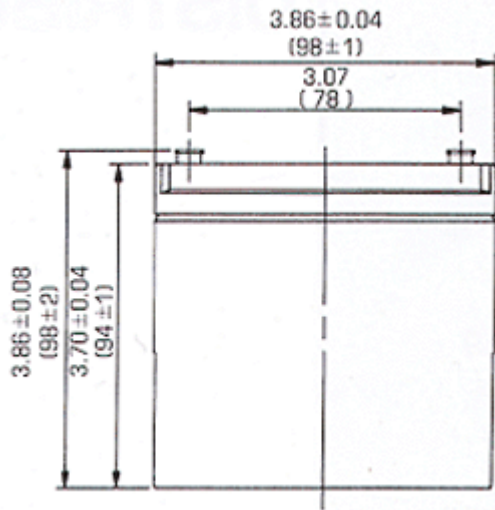

		104°F (40°C) Discharge —4°F (—20°C) to 122°F (50°C) Storage —4°F (—20°C) to 104°F (40°C)
12	Case Material	Synthetic resin (ABS)
13	Standard Terminal	F2: AMP Faston type 250
CHARGING METHODS		
CYCLIC USE: Maximum Initial Charge Current: 3 A Charging Voltage: 14.4V-14.7V Charge should be switched to float mode or disconnected when current drops to 120 mA.		
STANDBY USE: Maximum Initial Charge Current: 3 A Charge Voltage: 13.5V-13.8V		

[Click here for larger image](#)

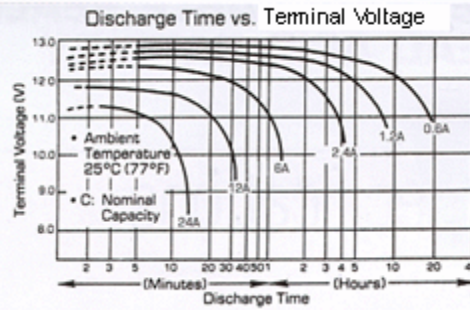

[Click here for larger image](#)

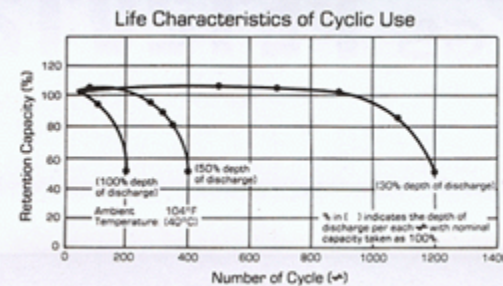

Click here for larger image

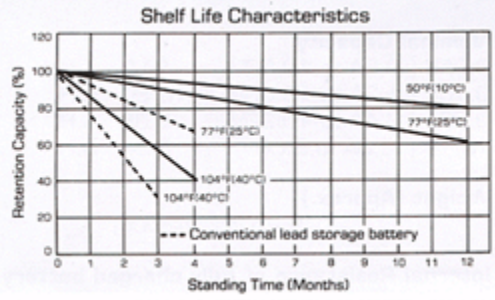

Click here for larger image

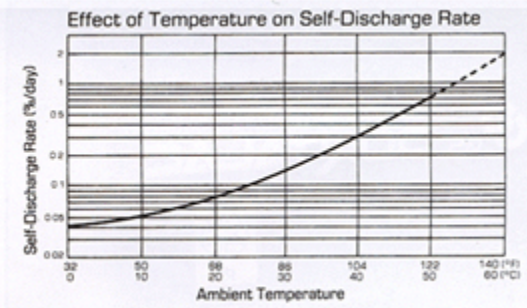

Click here for larger image

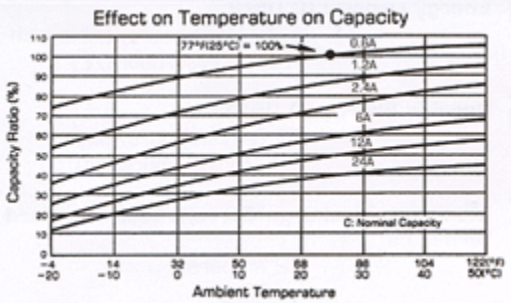

Click here for larger image

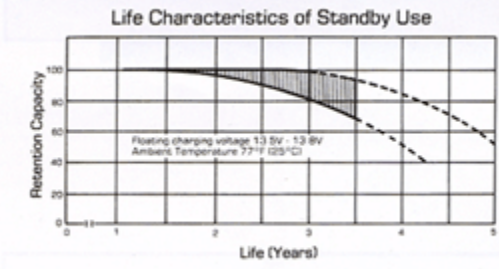

Click here for larger image

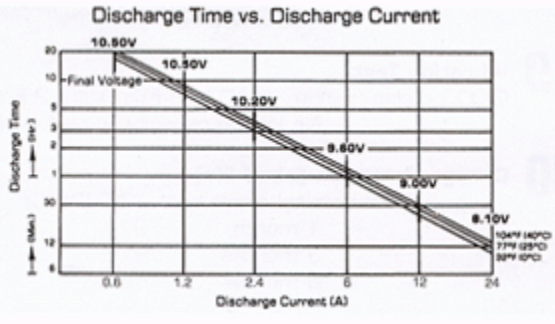

Copyright © 2004 GS Battery (USA) Inc. All rights reserved



[Back to the top...](#)