

Rechargeable Sealed Lead-Acid Battery

PS-12120L 12 Volt 12.0 Amp. Hrs.



Features:

- Absorbent Glass Mat (AGM) technology for superior performance.
- Valve regulated, spill proof construction allows safe operation in any position.
- Power/volume ratio yielding unrivaled energy density.
- Rugged plastic case and cover
- Approved for transport by air. D.O.T., I.A.T.A., F.A.A. and C.A.B. certified.
- U.L. recognized under file number MH 20845



PERFORMANCE SPECIFICATIONS

Nominal Voltage	12 volts (6 cells in series)
Nominal Capacity	
20 hour rate (600mA to 5.25 volts)	12.0 A.H.
10 hour rate (1.19A to 5.25 volts)	11.9 A.H.
5 hour rate (2.21A to 5.10 volts)	11.5 A.H.
1 hour rate (8.0A to 4.50 volts)	8.00 A.H.
15 min rate (25.5A to 4.50 volts)	6.40 A.H.
Approximate Weight	9.9 pounds (4.5 kg)
Energy Density (20 hour rate)	1.14 Watt-hours/cubic inch (69.0 Watt-hours/l)
Specific Energy (20 hour rate)	13.1 Watt-hours/pound (28.8 Watt-hours/kg)
Internal Resistance (Fully Charged Battery)	25 milliohms (approximately)
Maximum Discharge Current (≤ 7 Min.)	36 amperes
Maximum Short-Duration Discharge Current (≤ 10 Sec.)	120 amperes
Terminal configurations	Polarized quick disconnect tabs, Positive: 0.250" x 0.032" Negative: 0.187" x 0.032". Mate with AMP. INC FASTON "250/187" series
Shelf Life — % of nominal capacity at 68° F (20° C)	
1 Month.....	97%
3 Months.....	91%
6 Months.....	83%
Operating Temperature Range	
Charge	-4°F (-20°C) to 122°F (50°C)
Discharge	-4°F (-20°C) to 140°F (60°C)
Case	ABS Plastic

Shelf Life and Storage

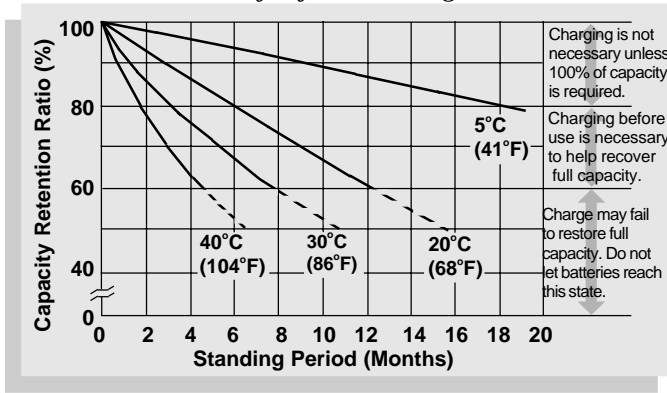

Discharge Characteristics

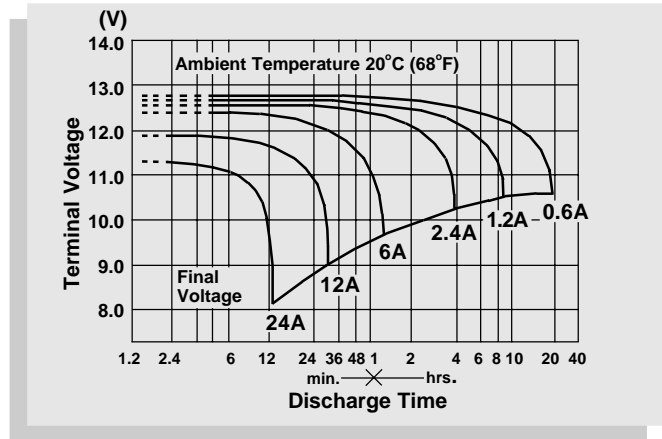

Life Characteristics in Stand-By Use

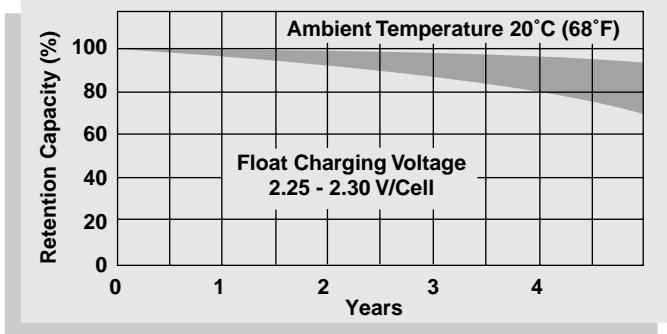

Discharge Time vs. Discharge Current

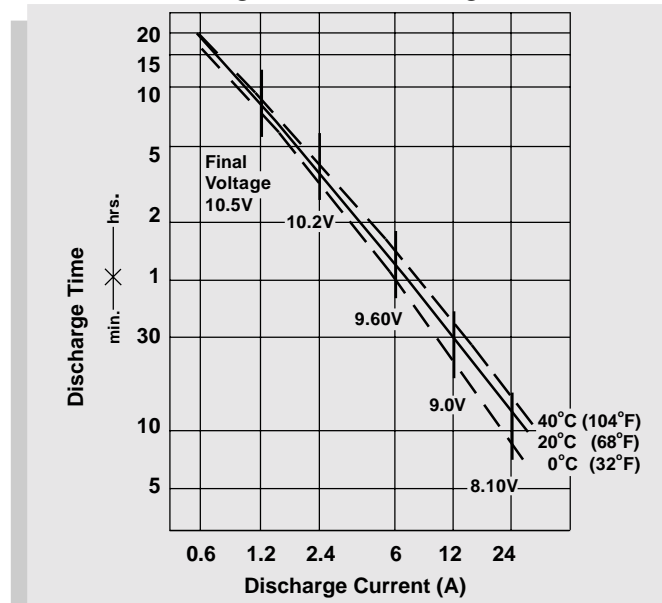

Life Characteristics in Cyclic Use

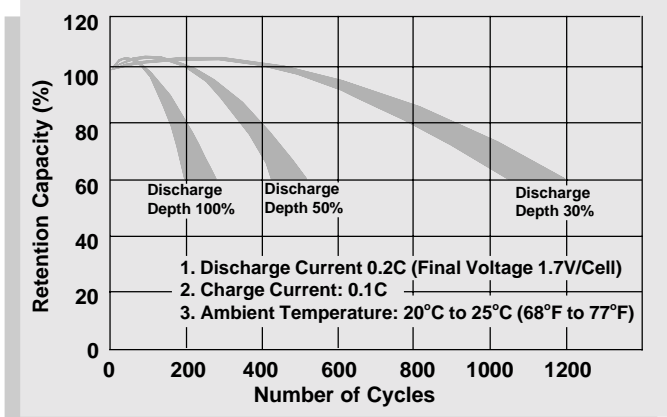

Physical Dimensions: in. (mm)

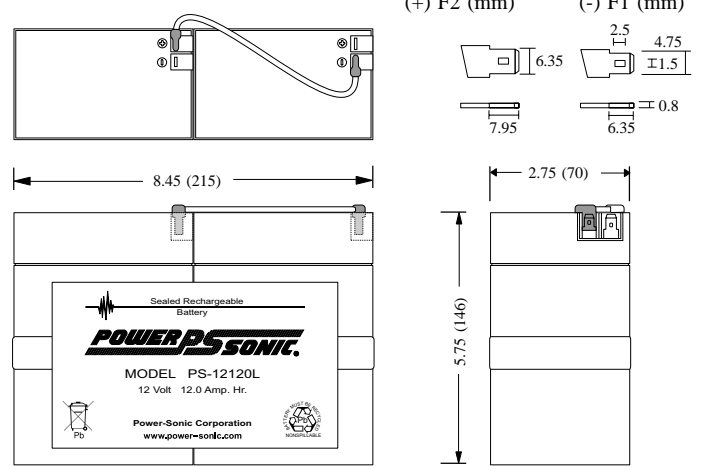

Tolerances are +/- 0.04 in. (+/- 1mm) and +/- 0.08 in. (+/- 2mm) for height dimensions. All data subject to change without notice.

CHARGING

Cycle Applications: Limit initial current to 2.4A. Charge until battery voltage (under charge) reaches 14.40 to 14.70 volts at 68°F (20°C). Hold at 14.40 to 14.70 volts until current drops to approximately 120mA. Battery is fully charged under these conditions, and charger should either be disconnected or switched to "float" voltage.

"Float" or "Stand-By" Service: Hold battery across constant voltage source of 13.50 to 13.80 volts continuously. When held at this voltage, the battery will seek its own current level and maintain itself in a fully charged condition.

NOTE: Due to the self-discharge characteristics of this type of battery, it is imperative that they be charged after 6-9 months of storage, otherwise permanent loss of capacity might occur as a result of sulfation.



CORPORATE OFFICE
7550 Panasonic Way
San Diego, CA 92154 USA
Tel: +1-619-661-2020
Fax: +1-619-661-3650
national-sales@power-sonic.com

CUSTOMER SERVICE
Tel: +1-619-661-2030
Fax: +1-619-661-3648
customer-service@power-sonic.com

SALES / INTERNATIONAL
Tel: +1-650-364-5001
Fax: +1-650-366-3662
battery@power-sonic.com

www.power-sonic.com