



PWL12V100 VRLA Battery

Valve Regulated Lead Acid Battery

Our patented PWL Valve Regulated Lead Acid Battery is designed for telecom and CATV back-up applications.

Specifications

- Grid Alloy: Lead Calcium Tin
- Case/Cover: PPE Resin (Flame Retardant, UL94 V-0, Halogen Free)
- Terminal: M6 Threaded Brass Insert

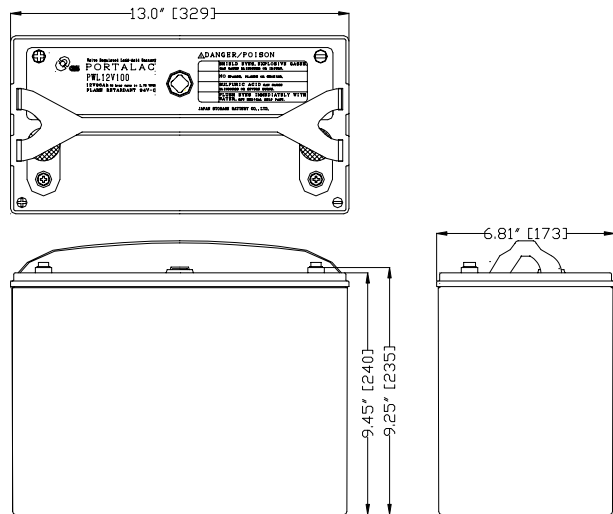

Model	Nominal Voltage (V)	Capacity 8HR (Ah)	Mass	Design Life @25degree C. (Year)	Dimensions			
					L	W	H	TH
PWL12V100	12	96	77 lbs 35kg	13	13.0" 329mm	6.81" 173mm	9.25" 235mm	9.45" 240mm

PWL12V100 Amperes to Final Volts per Cell Temp.: 25 degree C. (77F)											
F.V.	Discharge Time (hr)										
	20	12	10	9	8	7	6	5	4	3	2
1.75	5.20	8.50	10.0	11.0	12.0	13.3	14.9	17.3	20.5	25.7	34.7
1.80	5.04	8.10	9.72	10.7	11.9	13.1	14.8	16.9	20.1	25.0	34.2
1.85	4.68	7.83	9.36	10.2	11.2	12.4	14.0	16.2	19.3	23.9	32.4

Contact : **GS Battery U.S.A. Inc.** <http://www.gsbattery.com/>
US Headquarters
 1000 Mansell Exchange West, Suite 350
 Alpharetta GA, 30022

Phone (678) 762-4818
 Toll Free at (800) 472-2879
 Fax: (678) 739-2132

GS Battery (USA)