

DURACELL

PHOTO

ULTRA

CR-V3

Lithium/Manganese Dioxide

Li/MnO₂

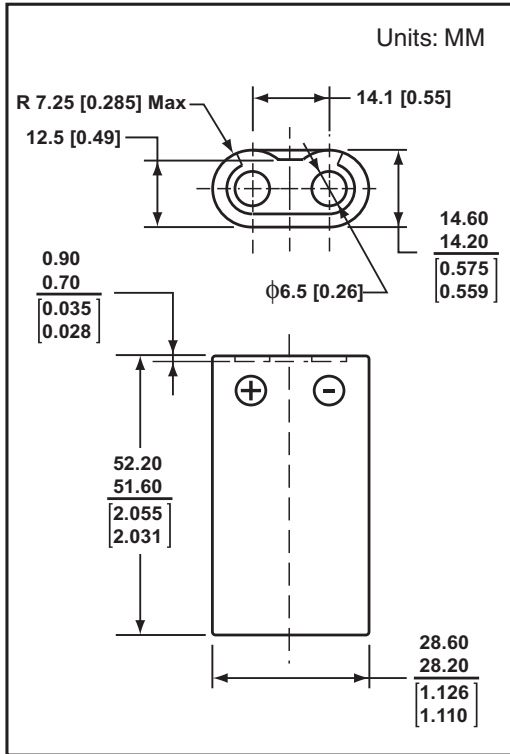

Nominal Voltage:	3.0 V
Typical Voltage:	3.1-3.3 V
Nominal Internal Impedance:	0.5 ohm @ 1kHz
Average Weight:	39 g
Volume:	21.9 cm. ³
Terminals:	Flat, Recessed Terminal Nickel Plated Steel
Operating Temp. Range:	-20°C to 60°C (-4°F to 140°F)
NEDA/ANSI :	5047
IEC:	TBD

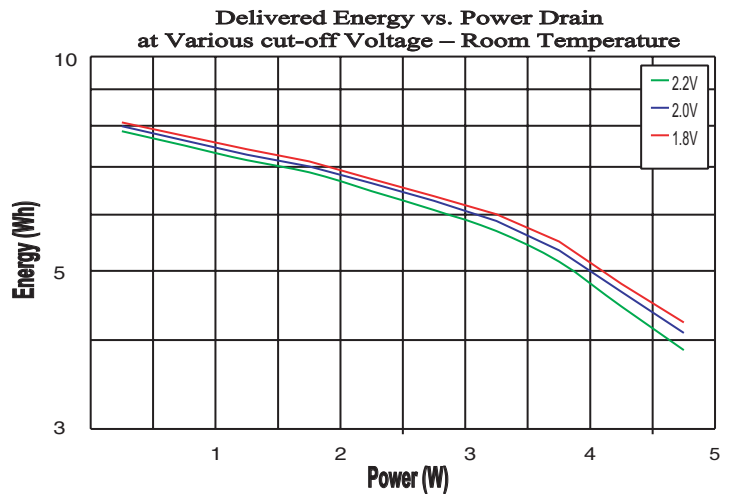

Duracell Ultra CR-V3 Typical Performance

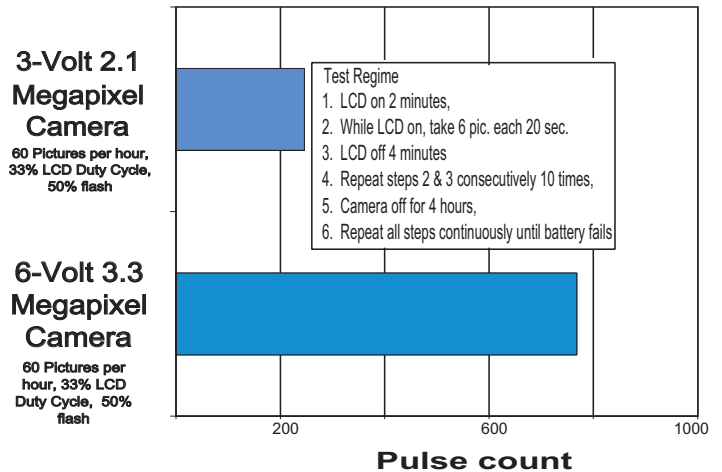
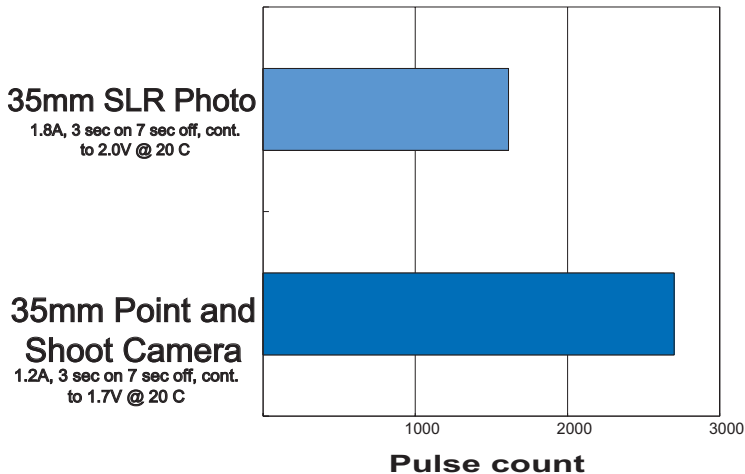

* Delivered capacity is dependent on the applied load, operating temperature and cut-off voltage. Please refer to the charts and discharge data shown for examples of the energy / service life that the battery will provide for various load conditions.

1.8 Amp, 3 Sec on / 7 sec off at Various Temperatures

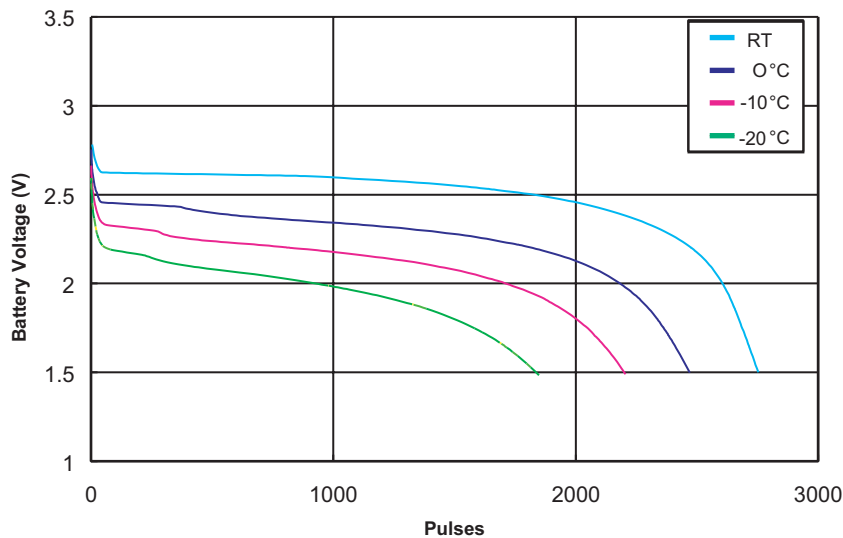

1.2 Amp, 3 Sec On / 7 Sec off at Various Temperatures

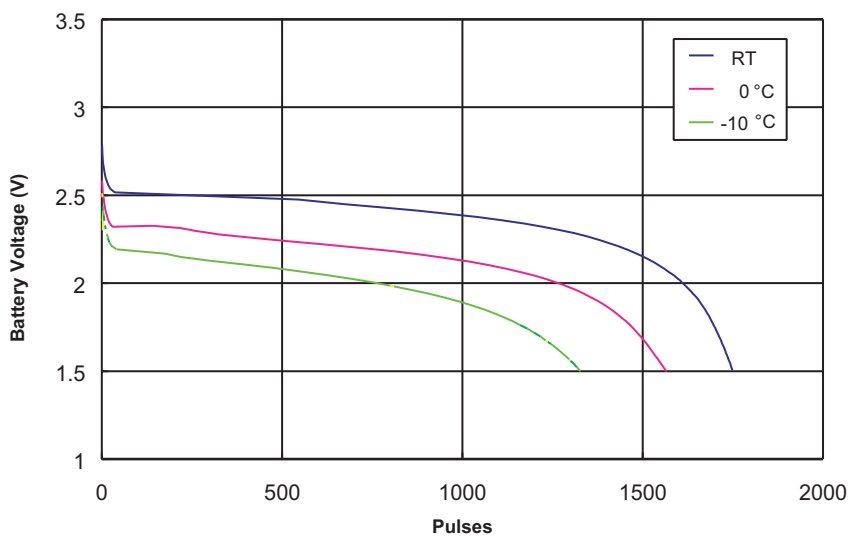

DURACELL®

BATTERIES

Berkshire Corporate Park
Bethel, CT 06801 U.S.A.
Telephone: Toll-free 1-800-544-5454
Internet: www.duracell.com

* Delivered capacity is dependent on the applied load, operating temperature and cut-off voltage. Please refer to the charts and discharge data shown for examples of the energy / service life that the battery will provide for various load conditions.