

Primary lithium battery

LSX 14500

3.6 V Primary lithium-thionyl chloride (Li-SOCl₂)
 High pulse
 AA-size coiled cell



Benefits

- High voltage, stable during most of the application's lifetime
- Superior voltage response in case of pulsing up to 700 mA, over a wide operating temperature range
- Possibility of end-of-life early detection
- Low self-discharge rate
(less than 2% after 1 year of storage at + 20°C)

Key features

- Stainless steel container and end caps
(low magnetic signature)
- Hermetic glass-to-metal sealing
- Non-flammable electrolyte
- Compliant with IEC 86-4 safety standard and EN 50020 intrinsic safety standard
- Underwriters Laboratories (UL) Component Recognition
(File Number MH 12609)
- Non-restricted for transport

Main applications

- Utility metering with shutting down valve option
- Alarm
- Tracking systems
- Automotive telematics
- Professional electronics
- Military

Cell size references

UM3 - R6 - AA

Electrical characteristics

(typical values relative to cells stored for one year or less at + 30°C max.)

Nominal capacity <i>(at 1 mA + 20°C 2.0 V cut off. The capacity restored by the cell varies according to current drain, temperature and cut off)</i>	2.1 Ah
Open circuit voltage (at + 20°C)	3.67 V
Nominal voltage (at 0.5 mA + 20°C)	3.6 V

Pulse capability: Typically up to 700 mA
(700 mA/0.1 second pulses, drained every 2 mn at + 20°C from undischarged cells with 10 µA base current, yield voltage readings above 3.0 V. The readings may vary according to the pulse characteristics, the temperature, and the cell's previous history. Fitting the cell with a capacitor may be recommended in severe conditions. Consult Saft)

Continuous current permitting 50% of the nominal capacity to be achieved at + 20°C with 2.0 V cut off.
(Higher currents possible, consult Saft)

150 mA

Storage *(recommended)* + 30°C (+ 86°F) max
(for more severe conditions, consult Saft)

Operating temperature range - 60°C/+ 85°C
(Operation at T different from ambient may lead to reduced capacity and lower voltage plateau readings)
 (- 76°F/+ 185°F)

Physical characteristics

Diameter <i>(max)</i>	14.65 mm (0.58 in)
Height <i>(max)</i>	50.3 mm (1.98 in)
Typical weight	17.5 g (0.6 oz)
Li metal content	approx. 0.75 g

Available termination suffix

CN, CNR
 2 PF, 3 PF, 3 PF RP
 CNA (AX)
 FL

radial tabs
 radial pins
 axial leads
 flying leads ...etc.



LSX 14500

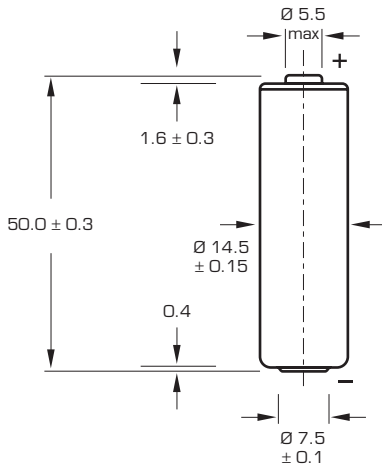

Dimensions in mm.

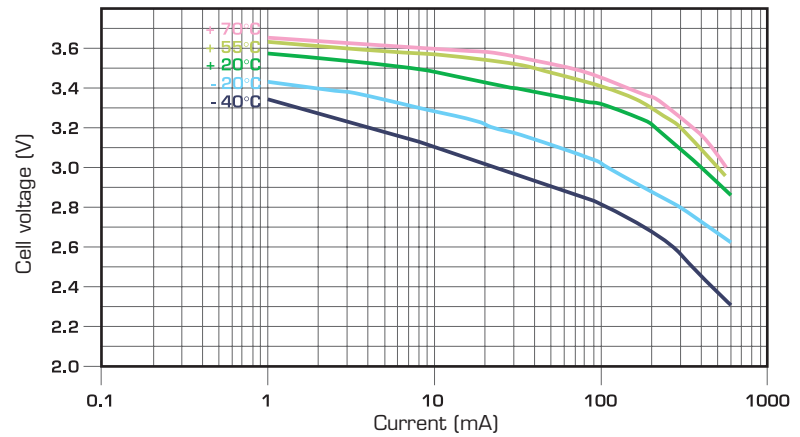

Voltage plateau versus Current and Temperature (at mid-discharge)

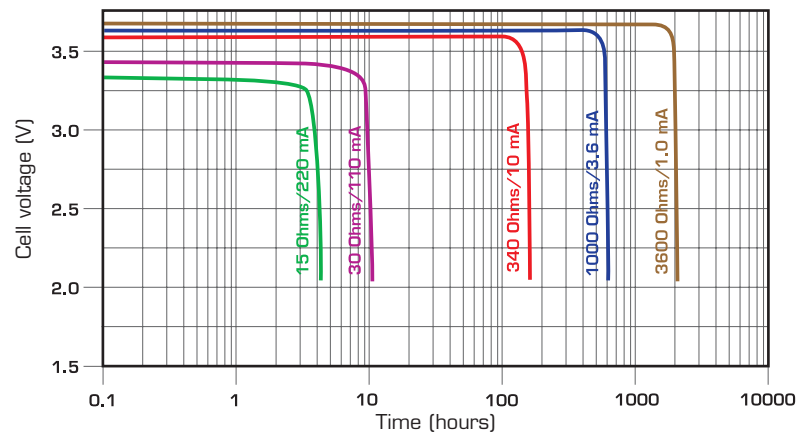

Typical discharge profiles at +20°C

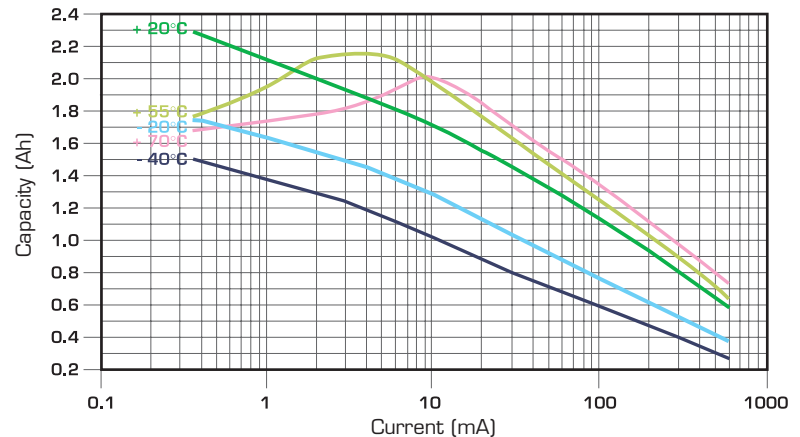

Restored Capacity versus Current and Temperature (2.0 V cut off)

Storage

- The storage area should be clean, cool (not exceeding + 30°C), dry and ventilated.

Warning

- Fire, explosion and severe burn hazard.
- Do not recharge, short circuit, crush, disassemble, heat above 100°C (212°F), incinerate, or expose contents to water.
- Do not solder directly to the cell (use tabbed cell versions instead).

Saft Specialty Battery Group

12, rue Sadi Carnot
93170 Bagnolet - France
Tel +33 (0)1 49 93 19 18
Fax +33 (0)1 49 93 19 69

www.saftbatteries.com

Doc. N° 31041-2-0706

Information in this document is subject to change without notice and becomes contractual only after written confirmation by Saft.

For more details on primary lithium technologies please refer to Primary Lithium Batteries Selector Guide Doc N° 31048-2.

Published by the Communications Department

Photo credit: Saft

Société anonyme au capital de 31 944 000 €

RCS Bobigny B 383 703 873

Produced by Arthur Associates



SAFT